

LCD 1970

Category I or Category III Appliance

(see Installation and Operation Manual for venting information)

CODE OPTIONS

CSD-1

UTC Lockout/Reset Control
Manual Reset LWCO

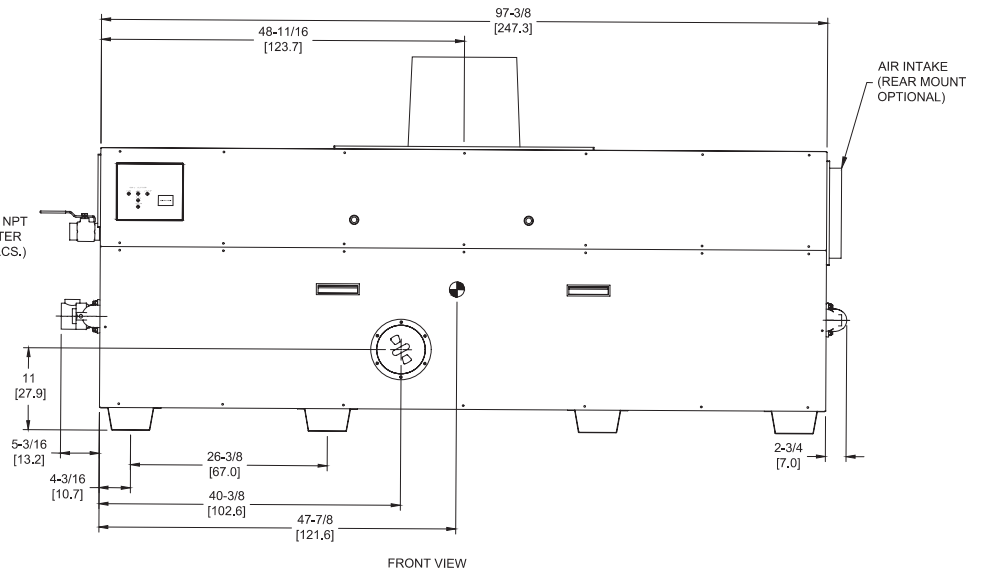
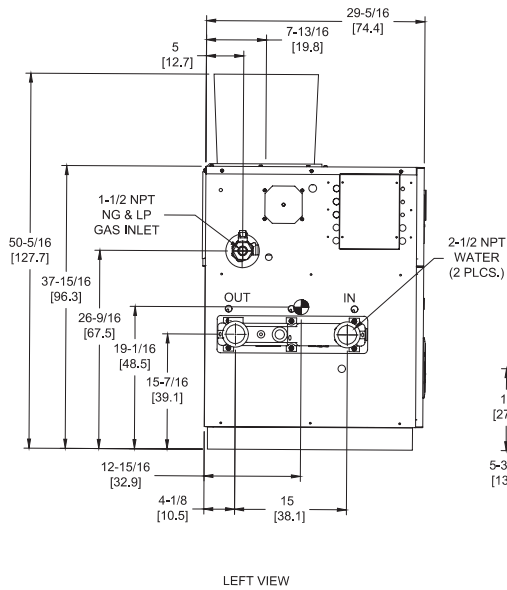
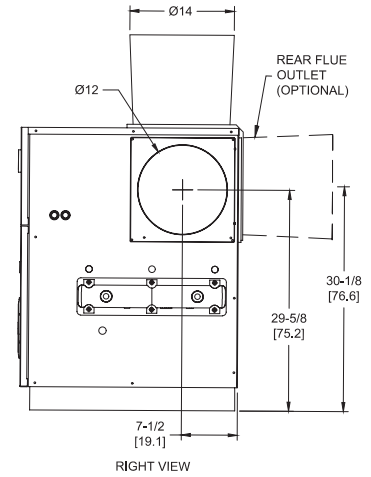
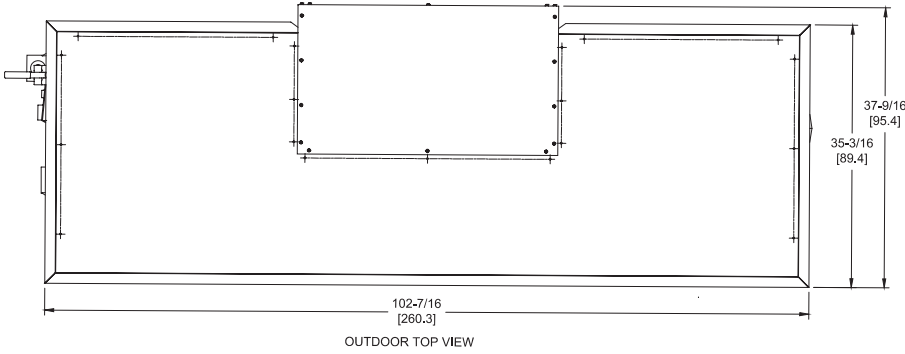

RSUB-23-F

Notes:

1. Dimensions are approximate and should not be used to "rough-in" equipment.
2. Dimensions are subject to change without notice.
3. All dimensions are in inches (cm).
4. Symbol indicates center of gravity.

SLCD-1970-8

BOILER CERTIFIED RATINGS & CAPACITIES

Fuel Type	Natural/Propane Gas	Boiler FLA	11.0*
Input BTU/hr.	1,970,000 / 577 kW	Min. Gas Pressure Required	7" WC**
Output BTU/hr.	1,615,400 / 473 kW	Max. Gas Pressure Allowed	14" WC
Electrical Requirements	120VAC/ 1 ph/ 60 hz	Operating Weight	1073 lbs. / 487 kg.

BOILER / WATER HEATER TRIM & CONTROLS

Main Gas Valve	Honeywell V8944B 1-1/2"	Pilot Valve	Honeywell VR8205Q
Firing Valve	Honeywell B200T1058 1-1/2"	Air Switch	Cleveland RSS-495
Safety Valve	Honeywell V48A 1-1/2"	Blower Motor	(2) 1/4 hp - FLA 10.2
Ignition Control	UTC 1003-61A	Relief Valve - LW	3/4" x 3/4" set @ 125 psi
Operating Control (LB/LW)	Jumo	Relief Valve - LB	1" x 1-1/4" set @ 50 psi
High Limit (LB/LW)	Jumo	Flow Switch	TACO

A.S.M.E.

ASME Sect IV Htg Surface	189 Sq. Ft. / 17.56 Sq. M.	Design Data	Max. 160 psig & 250°F
Water Volume	5.4 gal / 20.4 Liters		

* Add circulator amps.

** For incoming gas pressures lower than 7" WC natural or 11" WC propane, consult factory.

BOILER TEMPERATURE RISE / PRESSURE DROP

30°F / 16.7°C				35°F / 19.4°C			
Flow Rate		Pressure Drop		Flow Rate		Pressure Drop	
GPM	L/s	Ft	kPa	GPM	L/s	Ft	kPa
107.7	6.8	8.75	25.8	92.3	5.8	6.58	19.4

WATER HEATER HOURLY RECOVERY CAPACITY (GPH & LPH)

40°F	22°C	60°F	33°C	80°F	44°C	100°F	56°C	120°F	67°C	140°F	78°C
4872	18415	3248	12277	2436	9208	1949	7366	1624	6138	1392	5262

REP FIRM _____
SUBMITTED BY _____
JOB NAME _____
ARCHITECT _____
ENGINEER _____
CONTRACTOR _____
DATE _____

LCD 1970

Category I or Category III Appliance
(see Installation and Operation Manual for venting information)

RBI®
RELIABLE. BOLD. INNOVATIVE.

A Division of Mestek, Inc.
Westfield, MA 01085
(413) 564-5515